

RGF®

Guardian Air Mini

Mini AC/Heat Duct Air Purification System A Photohydroionization™ (PHI) Technology

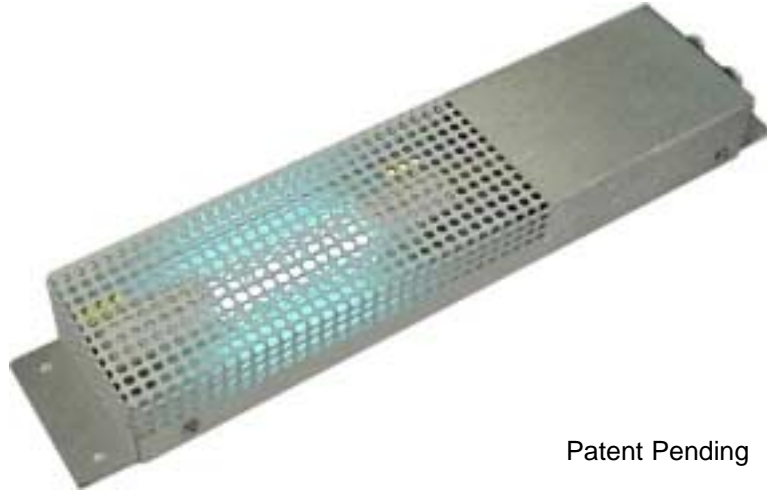

Patent Pending

The **Guardian Air Mini by RGF®** is designed to eliminate sick building syndrome risks by reducing odors, air pollutants, VOCs (chemical odors), smoke, mold bacteria and viruses*. The HVAC-PHI Cells are easily mounted into air conditioning and heating systems air ducts where most sick building problems start. When the HVAC system is in operation the HVAC-PHI Cell creates an Advanced Oxidation Process consisting of: Hydro-peroxides, ozonide ions, super oxide ions and hydroxide ions. All are friendly oxidizers. By friendly oxidizers we mean oxidizers that revert back to oxygen and hydrogen after the oxidation of the pollutant.

Why Use RGF's Photohydroionization™ Technology ?

Germicidal UV light rays have been used for decades by the medical industry as a method for destroying micro-organisms (germs, viruses, bacteria). UV light is dependable and can be easily installed in HVAC ducts or a plenum. Germicidal UV light is effective in reducing only the airborne micro-organisms that pass directly through the light rays. However, germicidal UV light has little to no effect on gases, vapors or odors. Photohydroionization Advanced Oxidation, on the other hand, is very effective on gases, vapors, VOCs and odors.

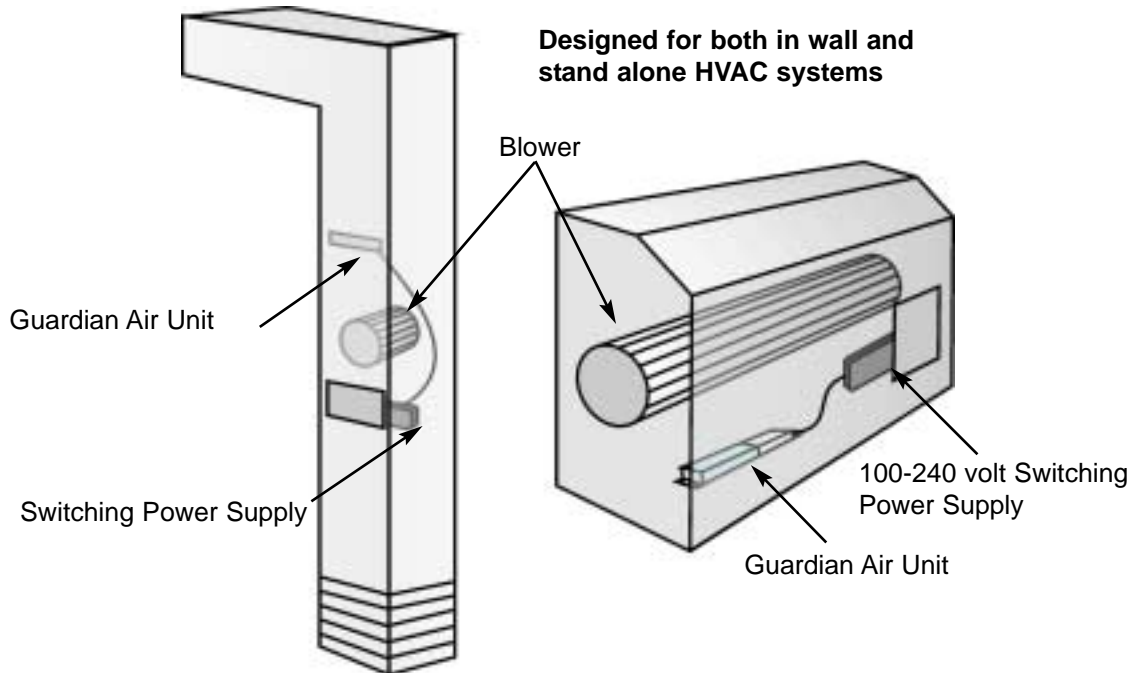

Actual lab tests showing up to 90% reductions of airborne bacteria and mold

The combination of safe low level ozone (O₃) and UV light enhanced by a hydrated quad-metallic compound target develops an advanced oxidation reaction that creates as well as reduces ozone to safe low levels. This process also produces hydro-peroxides, super oxide ions, ozonide ions and hydroxides. By engineering the proper UV light wavelength, in combination with a triple function, no maintenance unit, The PHI Cell provides safe hydro-peroxides, super oxide ions, ozonide ions and hydroxides to purify the air.

With the Guardian Air Mini Advanced Oxidation System, micro-organisms can be reduced by over 95%. Gases, VOCs and odors can also be reduced significantly, and the room will have ozonide ions, hydro-peroxides, super oxide ion and hydroxides which will help give your room fresh, clean and odor free air.

*UV, Hydro-peroxides and Ozone are recorded as effective in killing viruses however RGF has not performed clinical tests on viruses as there are thousands of strains

Guardian Air Mini

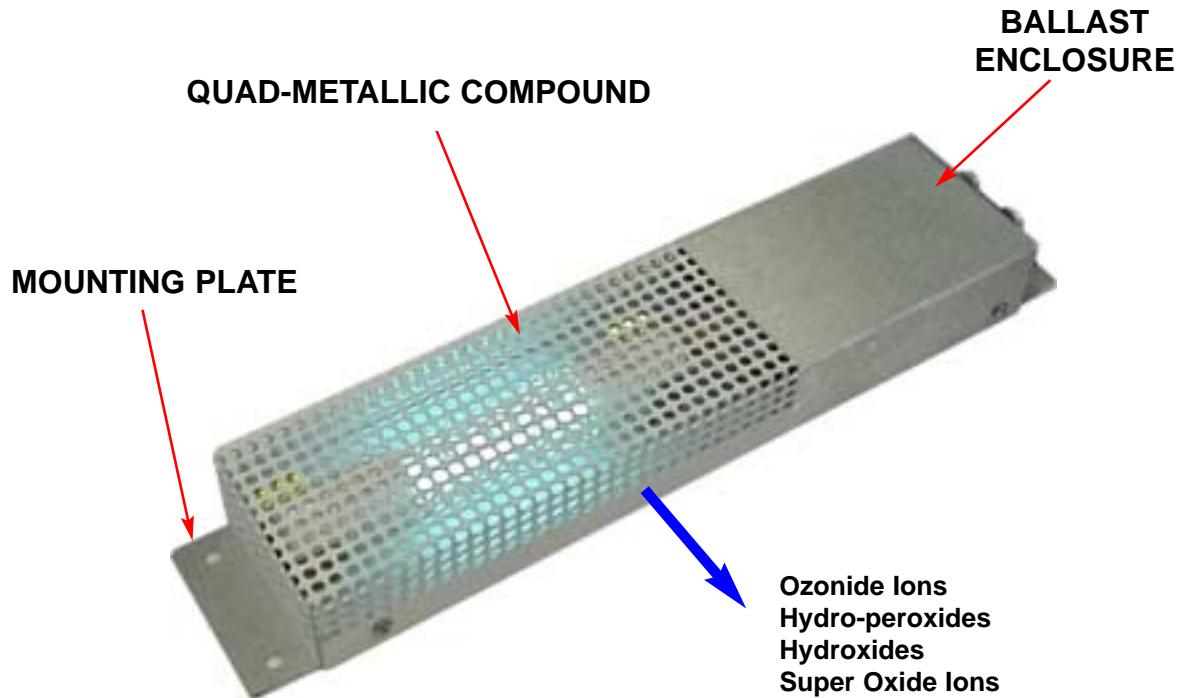

•Ozonide Ion Production:	0.02 ppm maximum
•Hydro-peroxides distribution:	distributed thru HVAC
•Super Oxide Ion distribution:	distributed thru HVAC
•Hydroxide Ion distribution:	distributed thru HVAC
•Installation:	installed in HVAC
•Electrical:	12 VDC Input 100-240 VAC Switching Power Supply
•Materials:	Aluminium housing
•Warranty:	3 years on parts
•PHI Cell Replacement	Recommended after 25,000 hrs

The **Guardian Air Mini** unit size is scaled to accommodate the various air flow rates of different HVAC systems. **Note:** It is recommended these units be installed by a licensed electrician.

Item #	HVAC Air Blower Size	Approx. Sq. Feet	Dimensions	Ship Wt.
MINI-HVAC-PHI-12	250* to 6,500 SCFM	Up to 1,000	2.25"W x 10.5"L x 1.25"D	1 lbs.

*Install unit in conjunction with an HVAC system utilizing a minimum air volume of 250 cfm.



RGF Environmental Group, Inc.
 3875 Fiscal Court West Palm Beach, Florida 33404
 800 842-7771 fax 561 848-9454 www.rgf.com